**Features:**

- ◆ 793nm wavelength
- ◆ 160W output power
- ◆ 200μm fiber core diameter
- ◆ 0.22 NA
- ◆ 1900nm~2100nm feedback protection

**Applications:**

- ◆ Fiber laser pumping
- ◆ Medical

## 793nm 160W Fiber Coupled Diode Laser

### RPK793-L9-160.0W-20022-FF

Specifications ( 25°C )		Symbol	Unit	RPK793-L9-160.0W-20022-FF		
				Minimum	Typical	Maximum
Optical Data <sup>(1)</sup>	CW Output Power	P <sub>o</sub>	W	160.0	-	-
	Center Wavelength	λ <sub>c</sub>	nm	793±3		
	Spectral Width(FWHM)	Δλ	nm	-	3	7
	Wavelength Shift with Temperature	Δλ/ΔT	nm/°C	-	0.3	-
Electrical Data	Electrical-to-Optical Efficiency	PE	%	-	42	-
	Threshold Current	I <sub>th</sub>	A	-	1.3	-
	Operating Current	I <sub>op</sub>	A	-	10.0	11.0
	Operating Voltage	V <sub>op</sub>	V	-	37.0	40.0
	Slope Efficiency	η	W/A	-	17	-
Fiber Data	Core Diameter	D <sub>core</sub>	μm	-	200	-
	Numeric Aperture	NA	-	-	0.22	-
	Fiber Length	L <sub>f</sub>	m	-	2.0	-
	Fiber Loose Tubing Diameter	-	mm	0.9		
	Minimum Bending Radius	-	mm	88	-	-
	Fiber Termination	-	-	FC-Ferrule		
Feedback Isolation	Wavelength Range	-	nm	1900~2100		
	Isolation	-	dB	-	30	-
Others	ESD	V <sub>esd</sub>	V	-	-	500
	Storage Temperature <sup>(2)</sup>	T <sub>st</sub>	°C	-20	-	70
	Lead Soldering Temp	T <sub>ls</sub>	°C	-	-	260
	Lead Soldering Time	t	sec	-	-	10
	Operating Case Temperature <sup>(3)</sup>	T <sub>op</sub>	°C	20	25	30
	Relative Humidity	RH	%	15	-	75

(1) Data measured under operation at nominal output power@25°C.

(2) A non-condensing environment is required for operation and storage.

(3) Operating temperature defined by the package case. Acceptable operating range is 20°C~30°C, but performance may vary.

## 793nm 160W Fiber Coupled Diode Laser

### RPK793-L9-160.0W-20022-FF

#### Package Dimensions (mm)

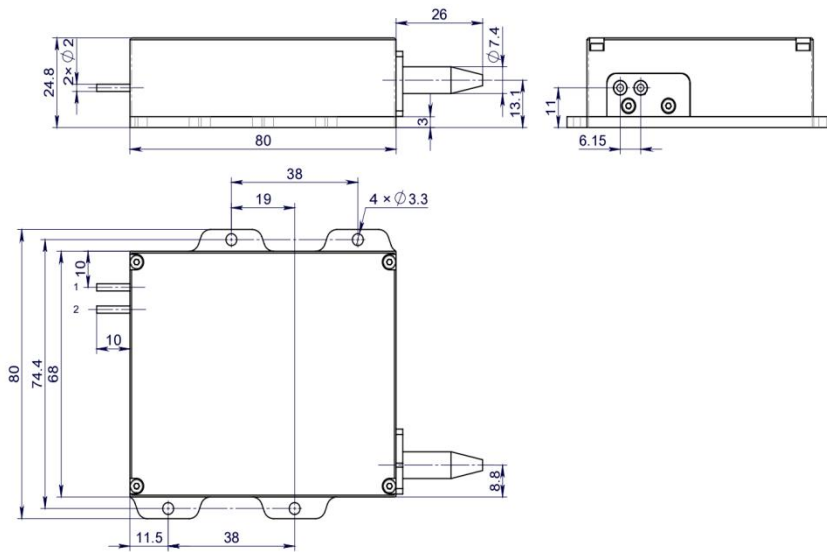

Pin	Function
1	LD ( + )
2	LD ( - )
3	Thermister(Optional)
4	Thermister(Optional)
5	PD(P)(Optional)
6	PD(N)(Optional)

#### OPERATING NOTES

- ◆ Avoid eye and skin exposure to direct radiation during operation.
- ◆ ESD precautions must be taken during storage, transportation and operation.
- ◆ Short-circuit is required between pins during storage and transportation.
- ◆ Please connect pins to wires by solder instead of using socket when operation current is higher than 6A. Soldering point should be close to the middle of the pins. Soldering temperature should be lower than 260°C and time shorter than 10 second.
- ◆ Make sure the fiber output end is properly cleaned before operation of laser. Follow safety protocols to avoid injury when handling and cutting the fiber.
- ◆ Use constant current power supply to avoid surge current during operation.
- ◆ Laser diode must be used according to the specifications.
- ◆ Laser diode must work with good cooling.
- ◆ Operation temperature ranges from 20°C to 30°C .
- ◆ Storage temperature ranges from -20°C to +70°C.



**Declaration:** information and specifications contained herein are deemed to be reliable and accurate. BWT Beijing reserves the right to change, alter or modify the design and specifications of these products at any time without notice.21-1