

### Features :

- ◆ 808nm wavelength
- ◆ 4W output power
- ◆ 200μm fiber core diameter
- ◆ 0.22 NA
- ◆ Additional Functions:
  - Aiming beam
  - Fiber & Power monitor
  - Thermistor

### Applications :

- ◆ Medical use

## 808nm 4W Multi-Function Detachable Diode Laser

### RPK808-11-4.000W-20022-SM

Specifications ( 25°C )		Symbol	Unit	RPK808-11-4.000W-20022-SM		
				Minimum	Typical	Maximum
Optical Data <sup>(1)</sup>	CW Output Power	P <sub>O</sub>	W	4	-	-
	Center Wavelength	λ <sub>c</sub>	nm	808±10		
	Wavelength Shift with Temperature	Δλ/ΔT	nm/°C	-	0.3	-
Electrical Data	Electrical-to-Optical Efficiency	PE	%	-	45	-
	Threshold Current	I <sub>th</sub>	A	-	1.5	-
	Operating Current	I <sub>op</sub>	A	-	5.5	6
	Operating Voltage	V <sub>op</sub>	V	-	1.8	2
	Slope Efficiency	η	W/A	-	1.0	-
Fiber Data	Core Diameter	D <sub>core</sub>	μm	-	200	-
	Numeric Aperture	NA	-	-	0.22	-
	Fiber Connector	-	-	SMA905		
Thermistor	-	R <sub>t</sub>	(K Ω)/(25°C)	-	10±3%	-
PD	-	PD	μA	100	-	2000
Others	ESD	V <sub>esd</sub>	V	-	-	500
	Storage Temperature <sup>(2)</sup>	T <sub>st</sub>	°C	-20	-	70
	Lead Soldering Temp	T <sub>is</sub>	°C	-	-	260
	Lead Soldering Time	t	sec	-	-	10
	Operating Case Temperature <sup>(3)</sup>	T <sub>op</sub>	°C	15	-	35
	Relative Humidity	RH	%	15	-	75
Aiming Beam	Output Power	P <sub>a</sub>	W	2	-	-
	Wavelength	λ <sub>a</sub>	nm	635±10		
	Voltage	V <sub>a</sub>	V	-	2.3	2.6
	Current	I <sub>a</sub>	A	-	45	65

(1) Data measured under operation output at 4W@25°C.

(2) A non-condensing environment is required for operation and storage.

(3) Operating temperature defined by the package case. Acceptable operating range is 15°C~35°C, but performance may vary.

## 808nm 4W Multi-Function Detachable Diode Laser

### RPK808-11-4.000W-20022-SM

#### Package Dimensions (mm)

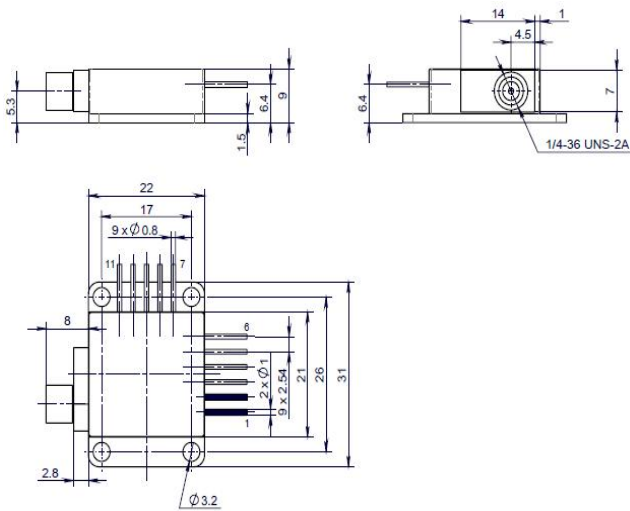

Pin	Function
1	LD(+)
2	LD(-)
3	PD(N)
4	PD(P)
5	Aiming Beam(-)
6	Aiming Beam(+)
7	Thermistor
8	Thermistor
9	FCD PD(P)
10	FCD LED(+) & FCD PD(N)
11	FCD LED(-)

#### OPERATING NOTES

- ◆ Avoid eye and skin exposure to direct radiation during operation.
- ◆ ESD precautions must be taken during storage, transportation and operation.
- ◆ Short-circuit is required between pins during storage and transportation.  
to the middle of the pins. Soldering temperature should be lower than 260°C and time shorter than 10 second.  
cutting the fiber.
- ◆ Laser diode must work with good cooling.
- ◆ Operation temperature ranges from 15°C to 35°C .
- ◆ Storage temperature ranges from -20°C to +70°C.



**Declaration:** information and specifications contained herein are deemed to be reliable and accurate. BWT Beijing reserves the right to change, alter or modify the design and specifications of these products at any time without notice.24-1