

 PART NUMBER 0515L-21A
 ITEM NAME 515 NM SLM LASER (VBG DIODE; FREE-SPACE)

PRODUCT DATASHEET



DESCRIPTION

Green laser sources are often used for fluorescence excitation, Raman scattering, as well as for Ti:sapphire pumping applications. High long-term power stability is ensured by TEC thermal stabilization, thermal and optical feedbacks.

SPECIFICATIONS

Datasheet generated: 22 July 2019

Specification updated: 4 July 2019

Parameter	Minimum Value	Typical Value	Maximum Value
Central Wavelength, nm	514.5	514.6	514.7
Longitudinal modes	-	single	-
Spectral line width FWHM, pm	-	0.1 ¹	1
Output power, mW	-	40 ²	-
Side-mode suppression ratio (SMSR), dB	40	50	60
Power stability, % (RMS, 8 hrs)	-	0.2 ³	1
Power stability, % (peak-to-peak, 8 hrs)	-	2 ⁴	3
Noise, % (RMS, 20 Hz to 20 MHz)	-	0.8 ⁵	2
Transversal modes	-	TEM00	-
Beam Diameter at Aperture (1/e ²), mm	-	1	-
Beam divergence (full angle), mrad	-	1.1	-
M ² horizontal axis	-	1.2	1.4
M ² vertical axis	-	1.3	1.6
M ² effective	-	1.3	1.6
Polarization direction	-	Horizontal ⁶	-
Polarization contrast	1000	2000	5000
Control interface type	-	UART/USB	-
Operation mode	-	APC (CW)	-
Modulation bandwidth, MHz	-	optional ⁷	-
Input voltage, VDC	4.8	5	5.3
External power supply requirement	-	+5 V DC, 1.5 A	-
Dimensions, mm	-	50 x 30 x 18 ⁸	-

TYPICAL SPECTRUM

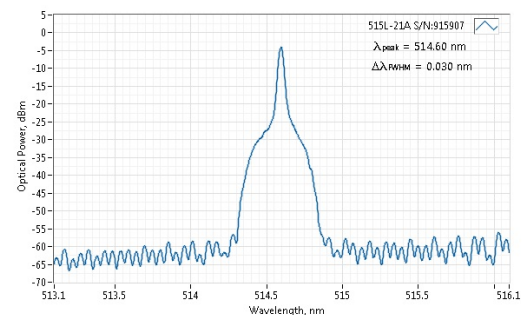

Typical spectrum of 0515 nm diode laser. Measured with 20 pm resolution.

TYPICAL NEAR FIELD

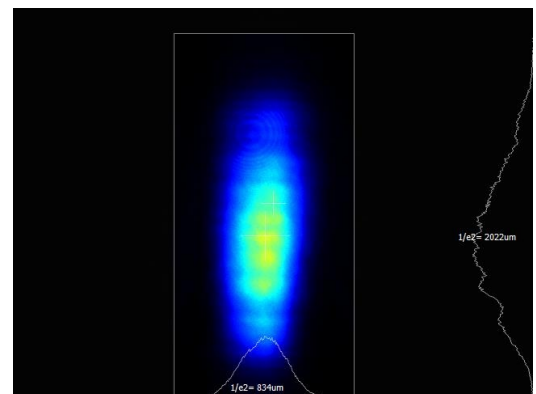

Typical near field (0.45 m from output aperture) beam profile. Non-circularized beam of a 0515 nm direct diode laser.

TYPICAL FAR FIELD

Beam height from the base, mm	9.9	10.4	10.9
Heat-sinking requirement, °C/W	-	1	-
Optimum heatsink temperature, °C	15	20	30
Warm up time, mins (cold start)	0.2	1	2
Temperature stabilization	-	Yes	-
Overheat protection	-	Yes	-
Storage temperature, °C (non-condensing)	-10	-	50
Net weight, kg	0.1	0.12	0.14
Max. power consumption, W	0.4	2	10
Warranty, months (op. hrs)	-	14 (10000) ⁹	-
RoHS	-	Yes	-
CE compliance	-	- General Product Safety Directive (GPSD) 2001/95/EC - (EMC) Directive 2004/108/EC	-
Laser Safety Class	-	3B	-
OEM lasers are not compliant with	-	IEC60825-1:2014 (compliant using additional accessories)	-
Country of origin	-	Lithuania	-

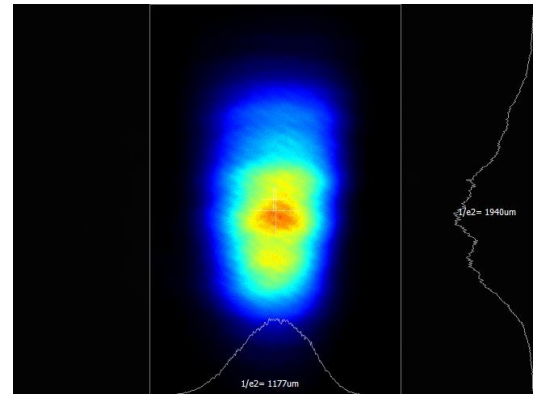

Typical far field (2.75 m from output aperture) beam profile. Non-circularized beam of a 0515 nm direct diode laser.

DRAWING

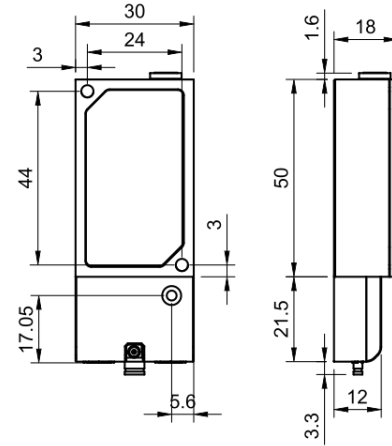

Matchbox (with breakout-box) dimensions

¹ Measured with a scanning Fabry-Perot interferometer having 7.5 Mhz resolution, with scanning frequency of about 10 Hz. Interferometer testing is not provided for each laser being manufactured, the standard test is OSA measurement with 10-20 pm resolution instead.

² The output power of SLM lasers shall not be tuned and SLM performance is not guaranteed at power ratings other than factory preset. However, the power setting capability is not disabled. External attenuators are recommended instead.

³ Long term power test is carried out using an optical power meter with an input bandwidth of 10 Hz. Actual measurement rate has a period of about 20 seconds to 1 minute.

⁴ Long term power test is carried out using an optical power meter with an input bandwidth of 10 Hz. Actual measurement rate has a period of about 20 seconds to 1 minute.

⁵ Noise level is measured with a fast photodiode connected to an oscilloscope. The overall system bandwidth is from 2 kHz to 20 MHz.

⁶ For lasers without integrated optical isolators.

⁷ TTL digital modulation up to 10 MHz.

⁸ Excluding control interface pins and an output window/fiber assembly.

⁹ Whichever occurs first. The laser has an integrated operational hours counter.

Note: Product specifications are subject to change without prior notice to improve reliability, function or design or otherwise.