

 PART NUMBER 0785L-14A
 ITEM NAME 785 NM LASER (DIODE; MM FIBER)

PRODUCT DATASHEET

DESCRIPTION



785 nm laser module is fiber coupled to a MM fiber and can emit up to 150 mW of optical power. As a standard this laser is provided with 1 m length, FC/PC fiber.

SPECIFICATIONS

Last edited on: 24 January 2019

Parameter	Minimum Value	Typical Value	Maximum Value
Central Wavelength, nm	782	785	788
Longitudinal modes	-	multimode	-
Spectral line width FWHM, nm	-	0.2	0.5
Output power, mW	-	150 ¹	-
Power stability, % (RMS, 8 hrs)	-	1 ²	2
Power stability, % (peak-to-peak, 8 hrs)	-	2 ³	3
Noise, % (RMS, 20 Hz to 20 MHz)	-	0.25 ⁴	0.6
Transversal modes	-	Multiple	-
Control interface type	-	UART/USB	-
Operation mode	-	APC (CW)	-
Modulation bandwidth, MHz	-	optional ⁵	-
Input voltage, VDC	4.8	5	5.3
External power supply requirement	-	+5 V DC, 1.5 A	-
Dimensions, mm	-	50 x 30 x 18 ⁶	-
Fiber Length, m	0.95	1	1.1
Heat-sinking requirement, °C/W	-	1	-
Optimum heatsink temperature, °C	15	20	30
Warm up time, mins (cold start)	0.1	0.5	1
Temperature stabilization	-	Yes	-
Overheat protection	-	Yes	-
Storage temperature, °C (non-condensing)	-10	-	50
Net weight, kg	0.1	0.12	0.14
Max. power consumption, W	0.4	2	10

TYPICAL SPECTRUM

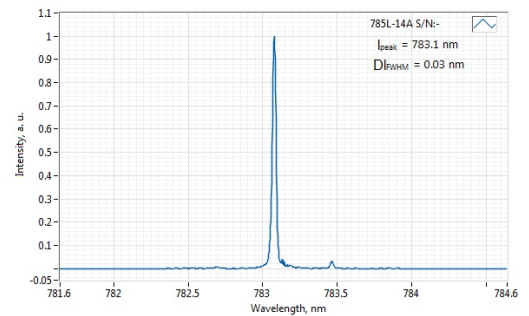

Typical spectrum of 0785 nm diode laser. Measured with 20 pm resolution.

DRAWING

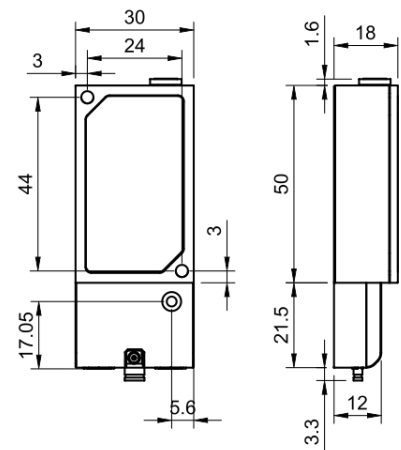

Matchbox (with breakout-box) dimensions

Warranty, months (op. hrs)	-	14 (10000) ⁷	-
RoHS	-	Yes	-
CE compliance	-	- General Product Safety Directive (GPSD) 2001/95/EC - (EMC) Directive 2004/108/EC	-
Laser Safety Class	-	3B	-
OEM lasers are not compliant with	-	IEC60825-1:2014 (compliant using additional accessories)	-
Country of origin	-	Lithuania	-

¹ The optical power can be tuned from virtually 0% to 100%. However, other specifications, such as central wavelength, power stability, noise, polarization ratio, beam shape, quality and circularity are not guaranteed at power levels other than factory preset power. Significantly worse power stability is to be expected at very low power levels, e.g. <3% from specified nominal power.

² Long term power test is carried out using an optical power meter with an input bandwidth of 10 Hz. Actual measurement rate has a period of about 20 seconds to 1 minute.

³ Long term power test is carried out using an optical power meter with an input bandwidth of 10 Hz. Actual measurement rate has a period of about 20 seconds to 1 minute.

⁴ Noise level is measured with a fast photodiode connected to an oscilloscope. The overall system bandwidth is from 2 kHz to 20 MHz.

⁵ TTL digital modulation up to 10 MHz.

⁶ Excluding control interface pins and an output window/fiber assembly.

⁷ Whichever occurs first. The laser has an integrated operational hours counter.

Note: Product specifications are subject to change without prior notice to improve reliability, function or design or otherwise.