

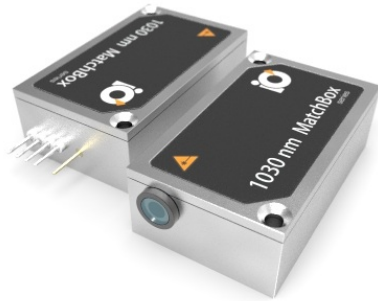

 PART NUMBER 1030L-21B
 ITEM NAME 1030 NM SLM LASER (DPSS; FREE-SPACE)

PRODUCT DATASHEET



DESCRIPTION

1030 nm laser module is a DPSS laser with Yb:YAG gain medium and high power pump. The SLM version of this laser is used for inspection of optical components at a wavelength, which is popular in high power fiber lasers and ultrashort pulse DPSS lasers. This version features a typical M² of 1.1.

SPECIFICATIONS

Last edited on: 24 January 2019

Parameter	Minimum Value	Typical Value	Maximum Value
Central Wavelength, nm	1029	1029.5	1030
Longitudinal modes	-	Single	-
Spectral line width FWHM, pm	-	0.2 ¹	1
Output power, mW	-	400 ²	-
Side-mode suppression ratio (SMSR), dB	40	50	60
Power stability, % (RMS, 8 hrs)	-	0.4 ³	1
Power stability, % (peak-to-peak, 8 hrs)	-	2 ⁴	3
Noise, % (RMS, 20 Hz to 20 MHz)	-	0.5 ⁵	1
Transversal modes	-	TEM ₀₀	-
Beam Diameter at Aperture (1/e ²), mm	-	1	-
Beam divergence (full angle), mrad	-	1.1	-
M ² effective	-	1.1	1.2
Polarization direction	-	Horizontal ⁶	-
Polarization contrast	-	polarized on request	-
Control interface type	-	UART/USB	-
Operation mode	-	APC (CW)	-
Modulation bandwidth, MHz	-	N/A ⁷	-
Input voltage, VDC	4.8	5	5.3
External power supply requirement	-	+5 V DC, 5 A	-
Dimensions, mm	-	50 x 30 x 18 ⁸	-
Beam height from the base, mm	9.9	10.4	10.9
Heat-sinking requirement, °C/W	-	0.5	-

TYPICAL SPECTRUM

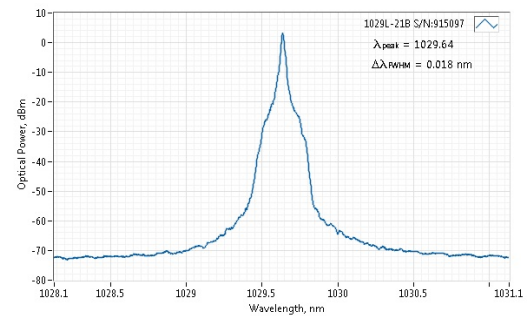

Typical spectrum of 1030 nm DPSS laser. Measured with 20 pm resolution.

TYPICAL NEAR FIELD

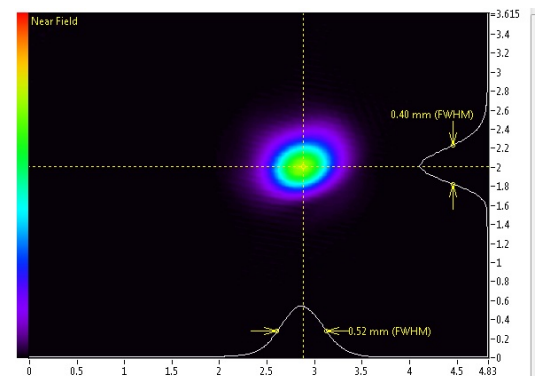

Typical near field (0.45 m from output aperture) beam profile. Circular beam of a 1030 nm DPSS laser.

TYPICAL FAR FIELD

Optimum heatsink temperature, °C	15	20	30
Warm up time, mins (cold start)	0.2	1	2
Temperature stabilization	-	Yes	-
Overheat protection	-	Yes	-
Storage temperature, °C (non-condensing)	-10	-	50
Net weight, kg	0.1	0.12	0.14
Max. power consumption, W	5	10	20
Warranty, months (op. hrs)	-	14 (10000) ⁹	-
Residual IR wavelength contrast	-	10	-
RoHS	-	Yes	-
CE compliance	-	- General Product Safety Directive (GPSD) 2001/95/EC - (EMC) Directive 2004/108/EC	-
Laser Safety Class	-	3B	-
OEM lasers are not compliant with	-	IEC60825-1:2014 (compliant using additional accessories)	-
Country of origin	-	Lithuania	-

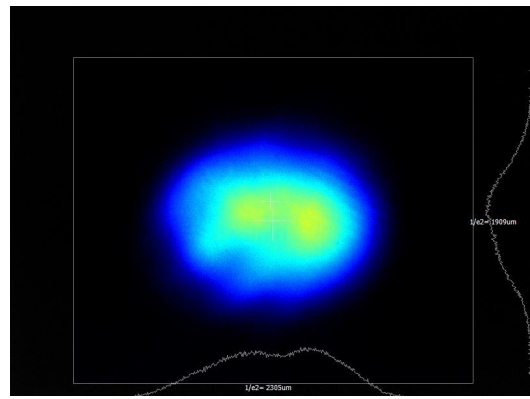

Typical far field (2.75 m from output aperture) beam profile. Circular beam of a 1030 nm DPSS laser.

DRAWING

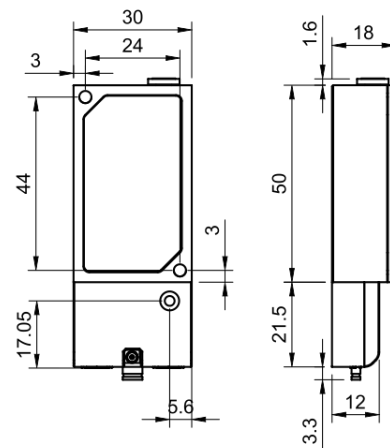

Matchbox (with breakout-box) dimensions

¹ Measured with a scanning Fabry-Perot interferometer having 7.5 Mhz resolution, with scanning frequency of about 10 Hz. Interferometer testing is not provided for each laser being manufactured, the standard test is OSA measurement with 10-20 pm resolution instead.

² The optical power of SLM lasers shall not be tuned and SLM performance is not guaranteed at power ratings other than the factory preset. However, the power setting capability is not disabled. External attenuators are recommended.

³ Long term power test is carried out using an optical power meter with an input bandwidth of 10 Hz. Actual measurement rate has a period of about 20 seconds to 1 minute.

⁴ Long term power test is carried out using an optical power meter with an input bandwidth of 10 Hz. Actual measurement rate has a period of about 20 seconds to 1 minute.

⁵ Noise level is measured with a fast photodiode connected to an oscilloscope. The overall system bandwidth is from 2 kHz to 20 MHz.

⁶ For lasers without integrated optical isolators.

⁷ SLM lasers shall not be modulated - use external modulators instead.

⁸ Excluding control interface pins and an output window/fiber assembly.

⁹ Whichever occurs first. The laser has an integrated operational hours counter.

Note: Product specifications are subject to change without prior notice to improve reliability, function or design or otherwise.