

2004nm DM LASER

EP2004-DM-B

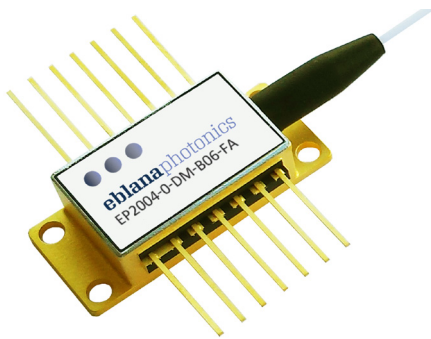

SUPERIOR CO₂ SENSING

Eblana Photonics EP2004-DM-B laser diode has been developed for precision sensing of Carbon Dioxide. Eblana's Discrete-Mode (DM) technology enables excellent SMSR performance and mode-hop free tuning at a highly competitive price.

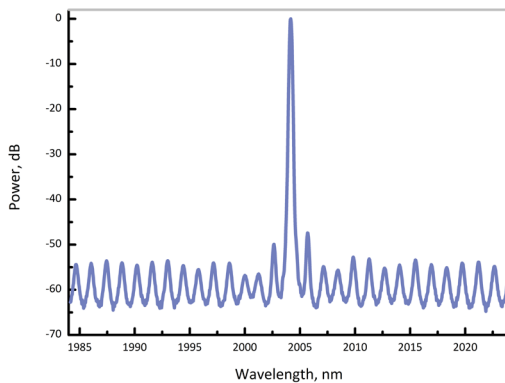

Typical optical spectrum at 25° C

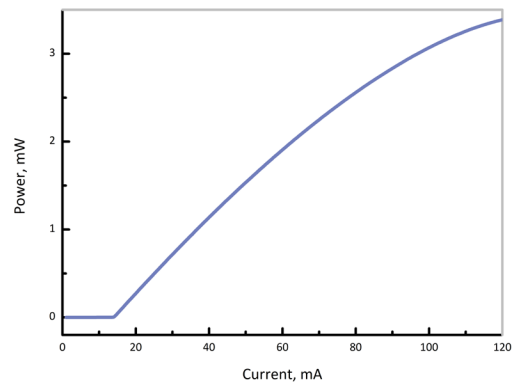

Output power as a function of bias current

ELECTRO-OPTICAL CHARACTERISTICS* (T_{SUB} = 25° C)

PARAMETER	SYMBOL	MIN	TYP	MAX	UNIT
Available Wavelength Range	λ	1970	2004	2051	nm
Wavelength Tolerance	λ_{spec}	$\lambda - 1$	λ	$\lambda + 1$	nm
Side Mode Supression Ratio	SMSR	30	40	-	dB
Threshold Current	I_{th}	-	20	40	mA
Output Power in fiber	P_f	-	3	-	mW
Optical linewidth	Δf	-	-	2	MHz
Temperature Tuning Coefficient	T_λ	-	0.1	-	nm/°C
Current Tuning Coefficient	I_λ	3	7	-	pm/mA
Slope Efficiency	SE	0.02	0.03	-	mW/mA
Thermistor Resistance	R_T	9.5	10	10.5	k Ω
Thermistor Temp. Coefficient	C	-	-4.4	-	%/°C

*CW bias unless otherwise stated

ABSOLUTE MAXIMUM RATINGS

PARAMETER	SYMBOL	MIN	MAX	UNIT
Forward Current	I_f	-	140	mA
Forward Voltage	V_f	-	1.6	V
TEC Current	I_{TEC}	-	1.2	A
Reverse Voltage LD	V_r	-	2	V
Case Temperature*	T_{Case}	-20	65	°C
Chip Submount Temperature	T_{Sub}	0	50	°C
Storage Temperature	$T_{storage}$	-40	85	°C

*For $T_{sub} < 25^{\circ}C$, Max Case Temperature should be derated to $T_{Case,Max} = T_{sub} + 40^{\circ}C$

PACKAGING

The EP2004-DM-B product series is offered in a 14-pin Butterfly package - Inquire for other packaging options. The standard package pinout is shown below, variations may be requested. mPD not included as standard.

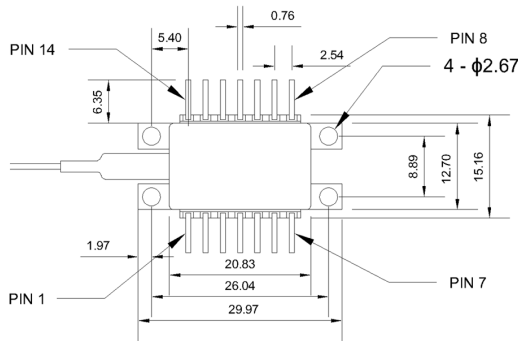

14-pin butterfly schematic

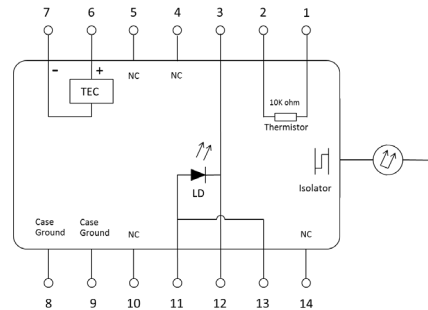

Standard "Pinout 06" option

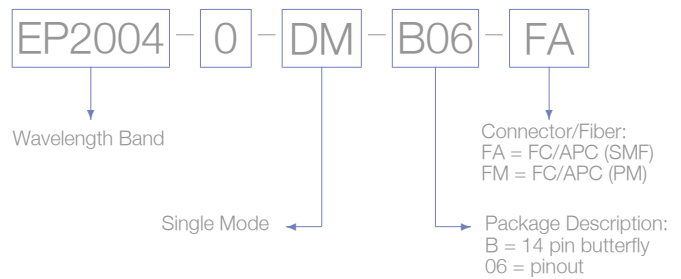

Laser Safety

This is a Class 3R Laser Product as defined by International Standard IEC 60825-1, Edition 3. Invisible Laser radiation is emitted from the end of the fiber or connector. Avoid direct eye exposure to the beam. Laser safety labels are not attached to the module due to space limitations but instead are affixed to the outside of the shipping carton.