

2108nm DM LASER

EP2108-DM-B

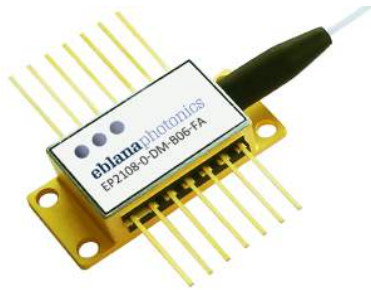

www.rpmclasers.com



ADVANCED N₂O SENSING

Eblana Photonics EP2108-DM-B laser diode is a cost effective, highly coherent laser source, designed using Eblana's discrete-mode (DM) technology. Excellent SMSR and tuning performance make it suitable for N₂O detection in TDLAS systems.

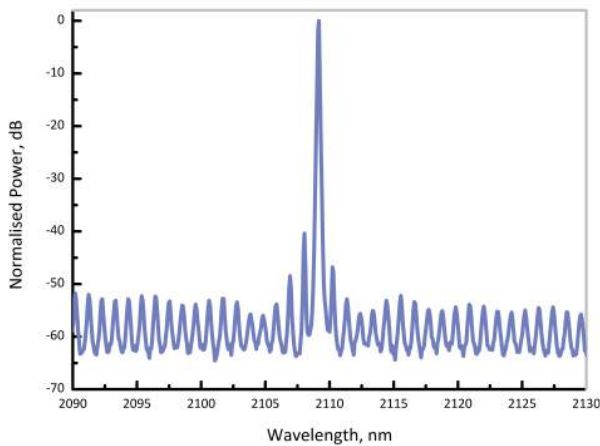

Optical Spectrum at 25°C

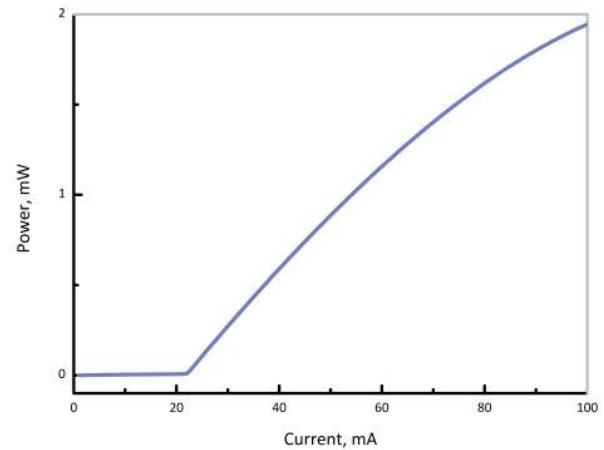

Output power vs bias current characteristics

ELECTRO-OPTICAL CHARACTERISTICS* (T_{SUB} = 25° C)

PARAMETER	SYMBOL	MIN	TYP	MAX	UNIT
Available Wavelength Range	λ	2050	2108	2128	nm
Wavelength Tolerance	λ_{spec}	$\lambda - 1$	λ	$\lambda + 1$	nm
Side Mode Supression Ratio	SMSR	30	40	-	dB
Threshold Current	I _{th}	-	30	40	mA
Output Power in fiber	P _f	1	1.5	-	mW
Optical linewidth	Δf	-	-	2	MHz
Temperature Tuning Coefficient	T _{λ}	-	0.1	-	nm/°C
Current Tuning Coefficient	I _{λ}	-	5	-	pm/mA
Slope Efficiency	SE	0.02	0.03	-	mW/mA
Thermistor Resistance	R _T	9.5	10	10.5	k Ω
Thermistor Temp. Coefficient	C	-	-4.4	-	%/°C

*CW bias unless otherwise stated

ABSOLUTE MAXIMUM RATINGS

PARAMETER	SYMBOL	MIN	MAX	UNIT
Forward Current	I_f	-	120	mA
Forward Voltage	V_f	-	1.6	V
TEC Current	I_{TEC}	-	1.2	A
Reverse Voltage LD	V_r	-	2	V
Case Temperature*	T_{Case}	-20	65	°C
Chip Submount Temperature	T_{Sub}	0	50	°C
Storage Temperature	$T_{storage}$	-40	85	°C

*For $T_{sub} < 25^{\circ}C$, Max Case Temperature should be derated to $T_{Case,Max} = T_{sub} + 40^{\circ}C$

PACKAGING

The EP2108-DM-B product series is offered in a 14-pin Butterfly package - Inquire for other packaging options. The standard package pinout is shown below, variations may be requested. mPD not included as standard.

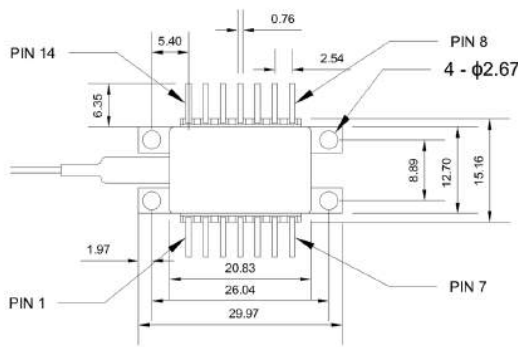

14-pin butterfly schematic

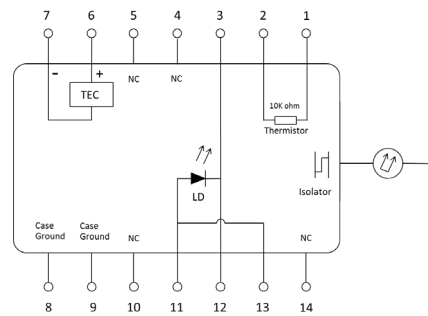

Standard "Pinout 06" option

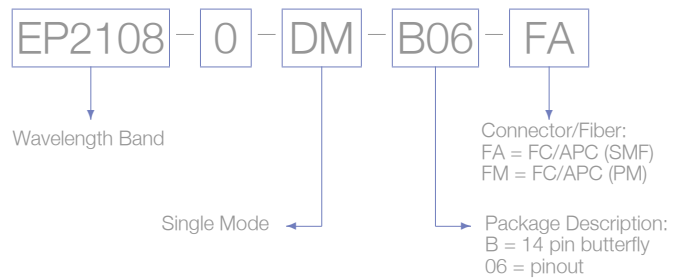

Laser Safety

This is a Class 3R Laser Product as defined by International Standard IEC 60825-1, Edition 3. Invisible Laser radiation is emitted from the end of the fiber or connector. Avoid direct eye exposure to the beam. Laser safety labels are not attached to the module due to space limitations but instead are affixed to the outside of the shipping carton.