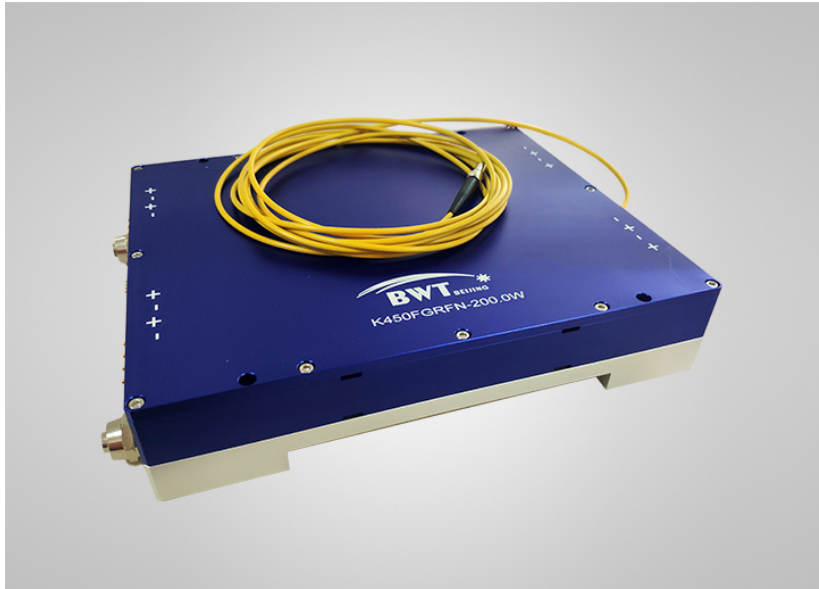

## 445nm 200W Fiber Coupled Diode Laser K445FGRFN-200.0W (Engineering Prototype)

---

**Features:**

- ◆ 445nm wavelength
- ◆ 200W output power
- ◆ 200 $\mu$ m fiber core diameter
- ◆ 0.22NA
- ◆ Cooling mode: water cooling

**Applications:**

- ◆ Material Processing
- ◆ 3D Printing

BWT Beijing's High Power Diode Laser Modules are manufactured by adopting specialized fiber-coupling techniques, resulting in volume products with a high efficiency, stability and superior beam quality. The products are achieved by transforming the asymmetric radiation from the laser diode chip into an output fiber with small core diameter by using special micro optics. Inspecting and burn-in procedures in every aspect come to a result to guarantee each product with the reliability, stability and long lifetime.

Our research staffs are constantly improving and innovating the processing technology in the producing process, based on the professional knowledge and experience accumulated in long-terms. We are also continuously developing new products to meet customers' specific needs.

At BWT Beijing, to provide high quality products with reasonable price is always our goal.

## 445nm 200W Fiber Coupled Diode Laser K445FGRFN-200.0W (Engineering Prototype)

Specifications(25°C)		Symbol	Unit	K445FGRFN-200.0W		
				Minimum	Typical	Maximum
Optical Data <sup>(1)</sup>	Total CW Output Power	$P_{bol}^{(4)}$	W	200	-	-
	Number of submodules	-	-	-	8	-
	Submodule CW Output Power	$P_o$	W	-	25	-
	Center Wavelength	$\lambda_c$	nm	445±10		
	Spectral Width (FWHM)	$\Delta\lambda$	nm	6		
	Wavelength Shift with Temperature	$\Delta\lambda/\Delta T$	nm/°C	-	0.1	-
	Wavelength Shift with Current	$\Delta\lambda/\Delta A$	nm/A	-	1	-
Electrical Data	Electrical-to-Optical Efficiency	PE	%	-	23	-
	Operating Current	$I_{bol}^{(4)}$	A	-	2.5	2.8
	Threshold Current	$I_{th}$	A	-	0.3	-
	Operating Voltage	$V_{op}$	V	-	44	50
	Slope Efficiency	$\eta$	W/A	-	10	-
	Power Supply Mode	-	-	-	8 modules	-
Fiber Data	Core Diameter	$D_{core}$	μm	-	200	-
	Cladding Diameter	$D_{clad}$	μm	-	220	-
	Numerical Aperture	NA	-	-	0.22	-
	Fiber Loose Tubing Diameter	-	mm	3mm Stainless Steel		
	Minimum Bending Radius	-	mm	88	-	-
	Fiber Termination	-	-	-	SMA905	-
Thermistor	-	Rt	(KΩ)/β(25°C)	-	10±3%/3450	-
Others	End of Life Current	$I_{eol}^{(5)}$	A	-	-	3.0
	End of Life Power	$P_{eol}^{(5)}$	W	16	-	-
	ESD	$V_{esd}$	V	-	-	500
	Storage Temperature <sup>(2)</sup>	$T_{st}$	°C	-20	-	70
	Lead Soldering Temp	$T_{ls}$	°C	-	-	260
	Lead Soldering Time	t	sec	-	-	10
	Operating Temperature <sup>(3)</sup>	$T_{op}$	°C	15	-	30
	Relative Humidity	RH	%	15	-	75

(1) Data measured under operation output at 200W@20°C.

(2) A non-condensing environment is required for operation and storage.

(3) Operating temperature defined by the thermistor. Acceptable operating range is 15°C~30°C, but performance may vary.

(4) Product delivery qualification standards:  $I_{beginning\ of\ life} \leq 3A$ ,  $P_{beginning\ of\ life} \geq 200W$ ;

(5) Within the warranty period, the product is considered qualified with  $I_{end\ of\ life} = 3A$ ,  $P_{end\ of\ life} \geq 160W$ .

## 445nm 200W Fiber Coupled Diode Laser K445FGRFN-200.0W (Engineering Prototype)

### Package Dimensions (mm)

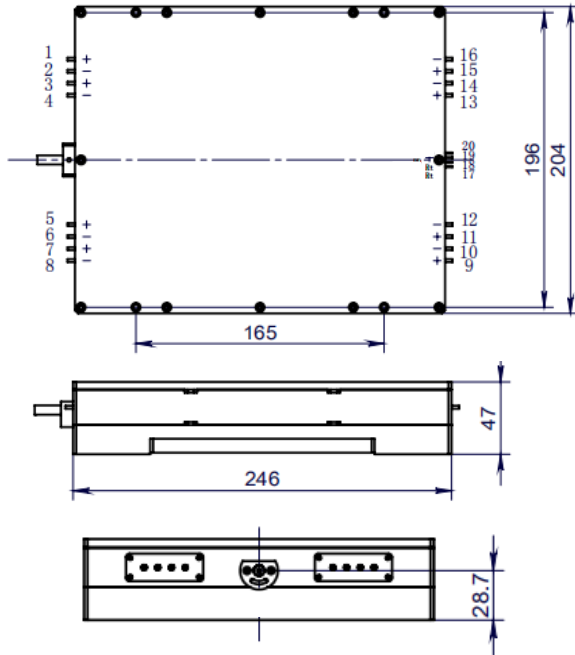

Pin	Function	Pin	Function
1	LD(+)	11	LD(+)
2	LD(-)	12	LD(-)
3	LD(+)	13	LD(+)
4	LD(-)	14	LD(-)
5	LD(+)	15	LD(+)
6	LD(-)	16	LD(-)
7	LD(+)	17	Thermistor*
8	LD(-)	18	Thermistor*
9	LD(+)	19	-
10	LD(-)	20	-

1. Thermistor is an optional function.
2. The 450nm 200W diode laser consists of 8 submodules ( 25W per module ) . Power can be supplied separately or in series.
3. The 450nm 200W diode laser has a symmetrical structure. Cooling water inlet and outlet can be switched freely.

### OPERATING NOTES

- ◆ Avoid eye and skin exposure to direct radiation during operation.
- ◆ ESD precautions must be taken during storage, transportation and operation.
- ◆ Short-circuit is required between pins during storage and transportation.
- ◆ Please connect pins to wires by solder instead of using socket when operation current is higher than 6A. Soldering point should be close to the root of the pins. Soldering temperature should be lower than 260℃ and time shorter than 10 second.
- ◆ Make sure the fiber output end is properly cleaned before operation of laser. Follow safety protocols to avoid injury when handling and cutting the fiber.
- ◆ Use constant current power supply to avoid surge current during operation.
- ◆ Laser diode must be used according to the specifications.
- ◆ Laser diode must work with good cooling.
- ◆ Operation temperature ranges from 15℃ to 30℃.
- ◆ Storage temperature ranges from -20℃ to +70℃.



**Declaration:** information and specifications contained herein are deemed to be reliable and accurate. BWT reserves the right to change, alter or modify the design and specifications of these products at any time without notice.19-1.