

808nm 8W Multi-Function Detachable Laser Diode K808F14CC-8.000W (Optional Product)



Features:

- ◆ 8W output power
- ◆ 808nm wavelength
- ◆ Standard fiber coupling for 200 μ m/0.22NA
- ◆ Customer options:
 - Aiming beam
 - Power PD
 - Thermistor
 - TEC

Applications:

- ◆ Medical use
- ◆ Material processing

BWT Beijing's High Power Diode Laser Modules are manufactured by adopting specialized fiber-coupling techniques, resulting in volume products with a high efficiency, stability and superior beam quality. The products are achieved by transforming the asymmetric radiation from the laser diode chip into an output fiber with small core diameter by using special micro optics. Inspecting and burn-in procedures in every aspect come to a result to guarantee each product with the reliability, stability and long lifetime.

Our research staffs are constantly improving and innovating the processing technology in the producing process, based on the professional knowledge and experience accumulated in long-terms. We are also continuously developing new products to meet customers' specific needs.

At BWT Beijing, to provide high quality products with reasonable price is our always goal.

808nm 8W Multi-Function Detachable Laser Diode

K808F14CC-8.000W (Optional Product)

Specifications(25°C)		Symbol	Unit	K808F14CC-8.000W		
				Minimum	Typical	Maximum
Parameter ⁽¹⁾	CW Output Power	P _o	W	8	-	-
	Threshold current	I _{th}	A	-	1.8	-
	Operating current	I _{op}	A	-	-	11
	Operating voltage	V _{op}	V	-	-	2.2
	Reverse Voltage	V _{re}	V	-	2.5	-
	Slope Efficiency	η	W/A	-	0.8	-
	Electrical-to-Optical Efficiency	PE	%	40	-	-
	Center wavelength	λ _c	nm	798	-	818
	Spectral width(FWHM)	δλ	nm	-	6	-
	Wavelength Shift with Temperature	-	nm/°C	-	0.3	-
Fiber Data	Buffer diameter	D _{buf}	μm	-	400	-
	Cladding diameter	D _{clad}	μm	-	220	-
	Core diameter	D _{core}	μm	-	200	-
	Numeric aperture	NA	-	-	0.22	-
Others	ESD	V _{esd}	V	-	-	500
	Storage temperature	T _{stg}	°C	-20	-	70
	Lead Soldering Temp	T _{is}	°C	-	-	260
	Lead Soldering Time	t	sec	-	-	10
	Operating case temperature	T _{op}	°C	15	-	35
	Relative Humidity	RH	%	15	-	75
PD Data	Current	I _{mo}	μA	100	-	1000
Thermistor	-	R _t	(K Ω)/β(25°C)	-	10±3%/3477	-
Aiming Beam Data	Output Power	P _a	mW	-	2	-
	Wavelength	I _a	nm	630	-	643
	Voltage	V _a	V	-	2.2	-
	Current	I _a	mA	-	45	65
TEC Data	Max. Current	-	A	-	6	-
	Max. Voltage	-	V	-	9.8	-

(1) Data measured under operation output at 8W.

808nm 8W Multi-Function Detachable Laser Diode K808F14CC-8.000W (Optional Product)

Characteristics

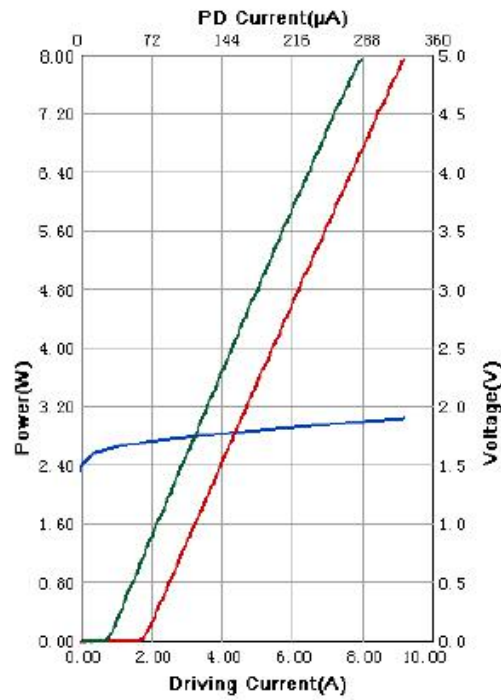

Typ. spectrum

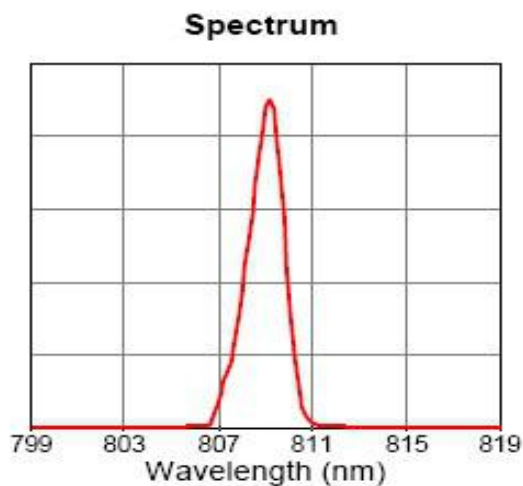

808nm 8W Multi-Function Detachable Laser Diode K808F14CC-8.000W (Optional Product)

Package Dimensions (mm)

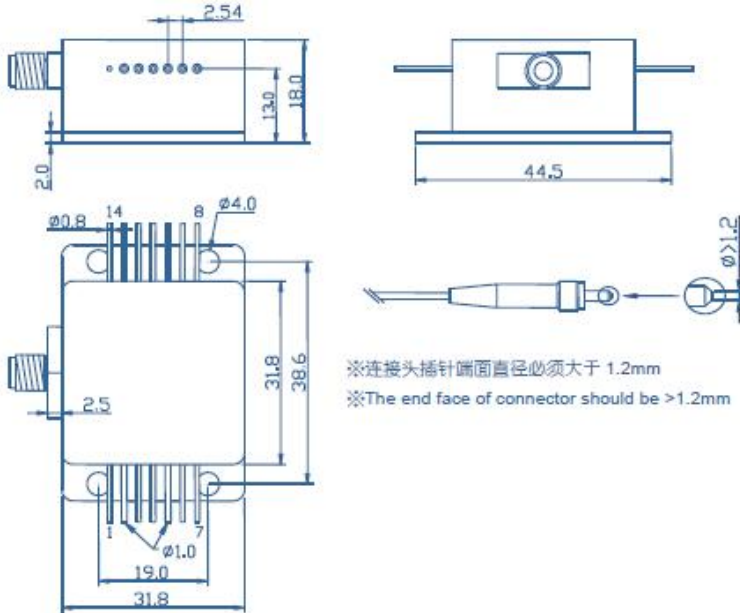

单位 (unit): mm

引脚	功能
1	Case
2	LD (+)
3	Thermistor*
4	Thermistor*
5	LD (-)
6	PD (P)*
7	PD (N)*
8	TEC (-)*
9	FCD PD (P)*
10	FCD LED (-)*
11	FCD LED (+)* FCD PD (N)*
12	Aiming Beam LD(+5V)*
13	Aiming Beam LD (0V)*
14	TEC (+)

※FCD: Fiber Connector Detector ※Optional Function

OPERATING NOTES

- ◆ Avoid eye exposure to direct or scattered radiation.
- ◆ ESD precautions must be taken.
- ◆ Please connect pins to wires by solder instead of using socket when operation current is higher than 6A.
- ◆ Soldering point should be close to the root of the pins. Soldering temperature should be lower than 260°C and time shorter than 10 second.
- ◆ Use constant current power supply. Avoid surge current.
- ◆ Laser diode must be used according to the specifications.
- ◆ Laser diode must work with good cooling.
- ◆ Operation temperature is 15°C~ 35°C.
- ◆ Storage: -20°C~ +70°C, all pins short-circuit.



Declaration: information and specifications contained herein are deemed to be reliable and accurate. BWT Beijing reserves the right to change, alter or modify the design and specifications of these products at any time without notice.