

878nm 30W High Power Fiber Coupled Diode Laser

K878BNXRN-30.00W

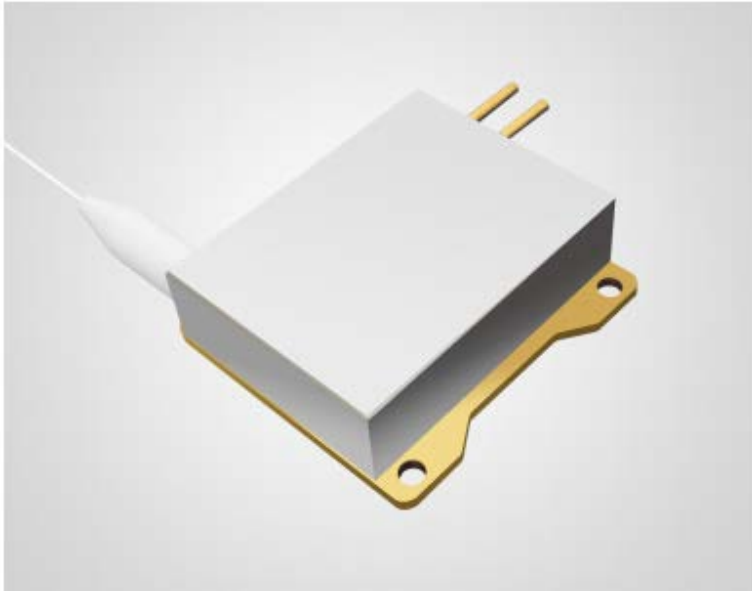

Features :

- ◆ 878.6nm wavelength
- ◆ 30W output power
- ◆ 400 μ m fiber core diameter
- ◆ 0.22N.A.
- ◆ 1040nm-1200nm feedback protection

Applications:

- ◆ Fiber laser pumping

BWT Beijing's High Power Diode Laser Modules are manufactured by adopting specialized fiber-coupling techniques, resulting in volume products with a high efficiency, stability and superior beam quality. The products are achieved by transforming the asymmetric radiation from the laser diode chip into an output fiber with small core diameter by using special micro optics. Inspecting and burn-in procedures in every aspect come to a result to guarantee each product with the reliability, stability and long lifetime.

Our research staffs are constantly improving and innovating the processing technology in the producing process, based on the professional knowledge and experience accumulated in long-terms. We are also continuously developing new products to meet customers' specific needs.

At BWT Beijing, to provide high quality products with reasonable price is our always goal.

878nm 30W High Power Fiber Coupled Diode Laser

K878BNXRN-30.00W

Specifications(20°C)		Symbol	Unit	K878BNXRN-30.00W		
				Minimum	Typical	Maximum
Optical Data ⁽¹⁾	CW-Output Power	P_o	W	-	30	-
	Center Wavelength	λ_c	nm	878.6±1		
	Spectral Width (FWHM)	$\Delta\lambda$	nm	< 1		
	Wavelength Shift with Temperature	$\Delta\lambda/\Delta T$	nm/ °C	-	0.03	-
Electrical Data	Electrical-to-Optical Efficiency	PE	%	-	45	-
	Operating Current	I_{op}	A	-	-	8
	Threshold Current	I_{th}	A	-	1.2	-
	Operating Voltage	V_{op}	V	-	-	11.2
	Slope Efficiency	η	W/A	-	4	-
Fiber Data	Core diameter	D_{core}	μm	-	400	-
	Cladding diameter	D_{clad}	um	-	440	-
	Buffer diameter	D_{buf}	um	-	730	-
	Numerical Aperture	N.A.	-	-	0.22	-
	Total Fiber Length	L_f	m	-	2	-
	Fiber Loose Tubing Diameter	-	mm	1.5		
	Minimum Bending Radius	-	mm	120	-	-
Feedback Isolation	Wavelength Range ⁽³⁾	λ	nm	1040~1200		
	Isolation	-	dB	-	30	-
Others	ESD	V_{esd}	V	-	-	500
	Storage Temperature (Non-operating)	T_{st}	°C	-20	-	70
	Lead Soldering Temp	T_{is}	°C	-	-	260
	Lead Soldering Time	t	sec	-	-	10
	Operating Case Temperature	T_{op}	°C	20	-	30
	Relative Humidity	RH	%	15	-	75

(1) Data measured under operation output at 30W.@20°C Case Temperature

(2) Operating temperature defined by the package housing. Acceptable operating range is 20 - 30C, but performance may vary.

878nm 30W High Power Fiber Coupled Diode Laser

K878BNXRN-30.00W

Package Dimensions (mm)

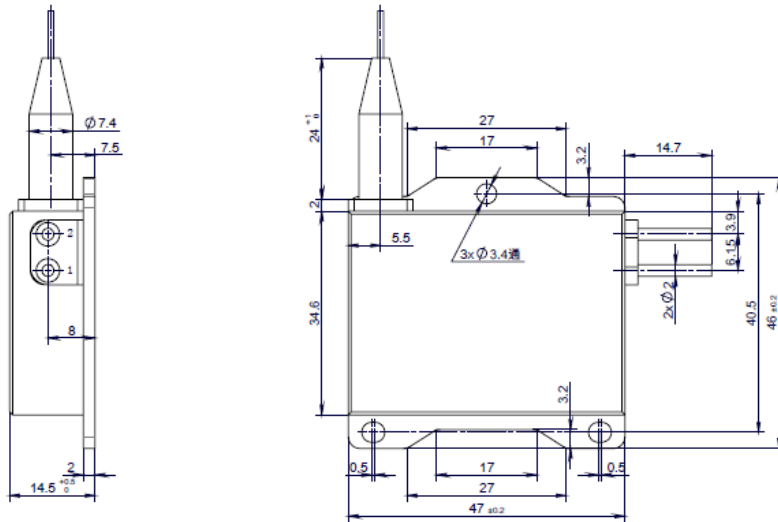

Pins	Function
1	LD (+)
2	LD (-)

*: Optional function.

OPERATING NOTES

- ◆ Avoid eye exposure to direct or scattered radiation.
- ◆ ESD precautions must be taken.
- ◆ Please connect pins to wires by solder instead of using socket when operation current is higher than 6A.
- ◆ Soldering point should be close to the root of the pins. Soldering temperature should be lower than 260°C and time shorter than 10 second.
- ◆ Use constant current power supply. Avoid surge current.
- ◆ Laser diode must be used according to the specifications.
- ◆ Laser diode must work with good cooling.
- ◆ Operation temperature is 20°C~ 30°C.
- ◆ Storage: -20°C~ +70°C, all pins short-circuit.



Declaration: information and specifications contained herein are deemed to be reliable and accurate. BWT Beijing reserves the right to change, alter or modify the design and specifications of these products at any time without notice.18-1