

# Quantas

## Q1-100

## DIODE PUMPED AIR-COOLED Q-SWITCHED LASER

### FEATURES

---

Up to **25 mJ** pulse energy at 1064 nm

---

**Air cooled** (no water)

---

Short pulse duration **< 10 ns**

---

**100 Hz** repetition rate

---

Built-in sync pulse generator for triggering of user equipment

---

Remote control via built-in **Ethernet** or **Wi-Fi** interface

---

Optional 2<sup>nd</sup>, 3<sup>rd</sup>, 4<sup>th</sup> or 5<sup>th</sup> harmonic generators

---

Optional attenuator for fundamental, second, third harmonic

---

Optional fiber coupled output

---

Guaranteed **> 1 Gshot** lifetime

---

### APPLICATIONS

---

Light Induced Breakdown Spectroscopy (LIBS)

---

LCD repair

---

Laser ablation

---

Time-of-Flight Spectroscopy (TOFS)

---

Light Induced Fluorescence (LIF) Spectroscopy

---

Flash photolysis

---

Matrix Assisted Laser Desorption/Ionization (MALDI)

---

Pulsed Light Deposition (PLD)

---

Light Detection And Ranging (LIDAR)

---

Remote sensing

---

Particle Image Velocimetry (PIV)

---



The new Quantas Q1-100 series diode pumped, fully air-cooled, Q-switched laser designed for wide range of applications that require high peak power pulses. Due good thermal properties of Nd:YAG crystal laser delivers up to 25 mJ at 100 Hz repetition rate.

This laser is ideal tool for applications like Light Induced Breakdown Spectroscopy (LIBS), LCD repair, semiconductor failure analysis, laser ablation, remote sensing and many others.

Less than 10 ns pulse duration allows efficient fundamental wavelength conversion to higher harmonics with shortest wavelength available of 213 nm. Wavelength extension into infrared range by use of OPO is available by request.

TEC based cooling eliminate risks associated with water cooling (like leaks, circuit shortening etc.) as well as reduce running cost due to no maintenance required.

Low jitter triggering pulses for user equipment are available with up to 300  $\mu$ s lead in internal triggering mode. If required, laser pulsing can be externally triggered from delay generator.

Laser controlled via built-in Ethernet port through web-server with option to add Wi-Fi adapter. It allows users to monitor and control laser remotely.

## SPECIFICATIONS 1)

MODEL	Quantas-1064				
	Q1A-50	Q1A-100	Q1B-100	Q1C-100	Q1D-100
Wavelength, nm	1064 nm				
Pulse energy	5 mJ	2.5 mJ	8 mJ	15 mJ	25 mJ
Typical pulse duration 2)	< 10 ns				
Pulse to pulse energy stability 3)	< 0.5 % RMS				
Power drift 4)	± 3.0 %				
Pulse repetition rate 5)	50 Hz	100 Hz 5)			
Beam profile	bell-shaped, > 75 % fit to Gaussian				
Beam divergence 6)	< 1.2 mrad				
Polarization	linear, horizontal at 1064 nm				
Typical beam diameter 7)	2.5 mm				
Jitter 8)	< 0.5 ns RMS				

### OPTIONAL HARMONICS GENERATOR MODULE 9)

Pulse energy	532 nm	355 nm	266 nm	213 nm
2.5 mJ	1.25 mJ	0.6 mJ	0.3 mJ	0.2 mJ
1.25 mJ	0.6 mJ	0.3 mJ	0.06 mJ	
4 mJ	2 mJ	1.5 mJ	0.5 mJ	
7.5 mJ	5 mJ	2.5 mJ	1 mJ	
12.5 mJ	6 mJ	3 mJ	1.5 mJ	

### OPTIONAL ATTENUATOR 10)

Wavelength	1064 nm, 532 nm, 355 nm
Attenuation range	5 – 95 %

### OPTIONAL FIBER COUPLED OUTPUT 11)

Wavelength	1064 nm or 532 nm
Max input pulse energy	up to 25 mJ 12)

### DIMENSIONS

Laser head ( W×L×H)	160 × 230 × 141 mm <sup>3</sup>
Harmonics generator module (W×L×H)	113 × 242 × 112 mm <sup>3</sup>
Controller unit (W×L×H)	160 × 70 × 140 mm <sup>3</sup>
Power adapter, typical (W×L×H)	80 × 120 × 60 mm <sup>3</sup>

### OPERATING REQUIREMENTS

Cooling requirements	air cooled (no any water)
Ambient temperature	15 – 30 °C
Relative humidity	10 – 80 % (non-condensing)
Mains voltage	90 – 230 V AC, single phase, 47 – 63 Hz 13)
Power consumption	< 50 W      < 100 W      < 150 W

1) Due to continuous improvements all specifications are subject to change. Unless stated otherwise all specifications are measured at 1064 nm and 100 Hz pulse repetition rate.

2) FWHM level at 1064 nm. Shorter pulse duration is available by request. Please inquire for detailed specifications.

3) Averaged from 30 second time interval.

4) Over 8 hour period after 20 minutes of warm-up time, when ambient temperature variation is less than ±2 °C.

5) Factory-set pulse repetition rate is fixed at max repetition rate shown in the table. Higher repetition rates are available, please inquire for more details.

6) Full angle measured at the 1/e<sup>2</sup> level.

7) Beam diameter is measured 20 cm from laser output at the 1/e<sup>2</sup> level.

8) In respect to Q-switch triggering edge of pulse.

9) Harmonics generator module is stand-alone unit optimized for specified output wavelength. Inquire for details if multiple wavelength output is needed.

10) External Motorized Variable Attenuator. Please inquire for attenuator built-in into harmonics generator module.

11) Fiber coupler is built-in into harmonics generator module. Please inquire for details.

12) For fiber core diameter of 550 μm. Smaller core fibers are available, inquire for specifications.

13) Laser can be powered from appropriate 28 V DC power source. Please inquire for details.



## DRAWINGS

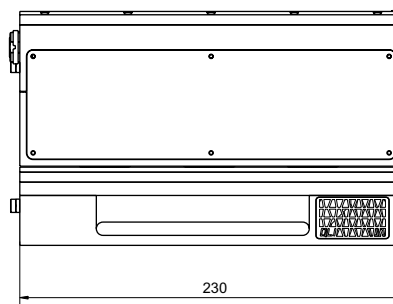
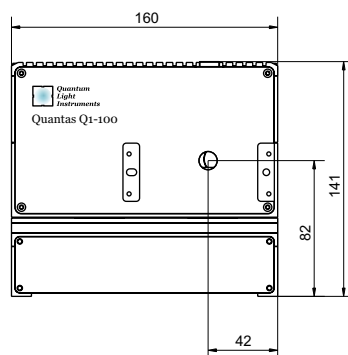

Laser head dimensions

